

GVF SERIES

Super Rigid Vertical CNC Turning Centers



THE ULTIMATE MACHINING POWER
WOODWAY

SUPER RIGID VERTICAL TURNING CENTERS

With leading technology and high quality components, the GVF series CNC vertical turning center combines a super rigid ram structure and high torque gear type spindle design to provide you heavy cutting abilities for large sizes that are superior to competitors' models in the aerospace and energy industry. Plus, with the optional live tooling spindle, Cf-axis control, and multi-purpose milling heads, turning, milling and drilling applications may be completed for both end surface and cylindrical surface to accomplish demanding turning applications of today and tomorrow.

- ▶ Enclosed splashguards keep chips and coolant contained for a safe clean working environment.
- ▶ Extra wide door enables large size work-pieces to be loaded onto the work table with a crown block providing easy loading and unloading operations.



(GVF-2023 model shown with FANUC Oi-TF controller)

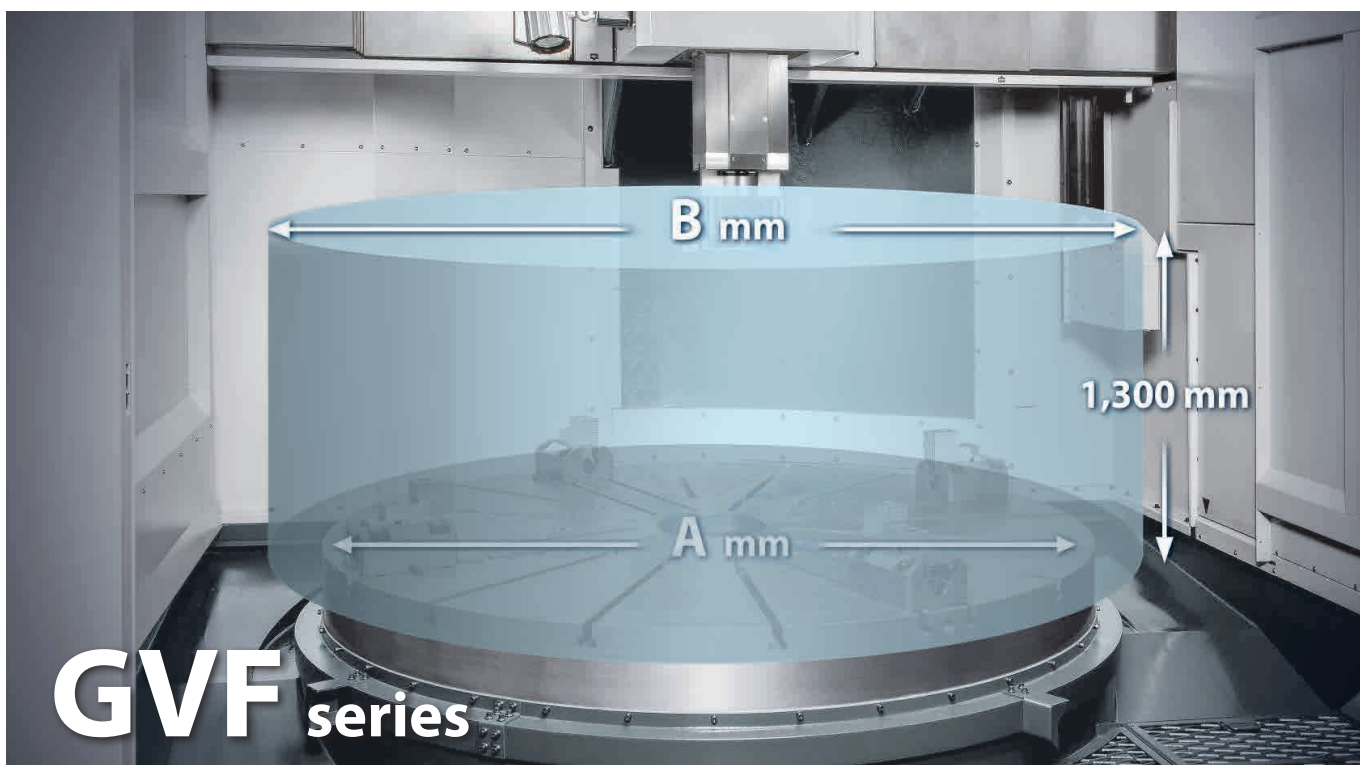

GVF series

A Table diameter

GVF-1112 : Ø1,000	GVF-1618 : Ø1,600
GVF-1214 : Ø1,250	GVF-2023 : Ø2,000
GVF-1215 : Ø1,250	

B Max. turning diameter

GVF-1112 : Ø1,200	GVF-1618 : Ø1,800
GVF-1214 : Ø1,400	GVF-2023 : Ø2,300
GVF-1215 : Ø1,500	

► The highly reliable BT50 12T / 16T / 24T umbrella type ATC system with max. tool weight 50 kg and max. load 360 kg for the magazine can easily fulfill complex workpiece machining applications.



► The standard coolant nozzle is around the spindle function and chip wash down coolant system. Chips can be easily brought out through the coolant tank and provides excellent cooling capabilities.

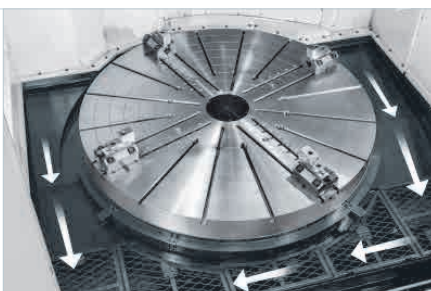

900 L coolant tank and right discharge chip conveyor

SUPER RIGID CONSTRUCTION

The fixed cross rail design is a reinforced rib column integrated with a cross rail that decreases wear and tear or damage problems, which greatly increase the rigidity of the head and dramatically enhance the ability of vibration suppression.

- ▶ By using Finite Element Analysis (FEA), optimal reinforced ribbings are directly cast into the bed and column structure. Mechanical rigidity has been increased by more than 30% when compared to conventional designs. The GVF series is capable of performing super heavy-duty turning and maintain long-term super high precision accuracy. More rigidity also means extended tool life.
- ▶ The super rigid bed and column are of MEEHANITE casting. It is capable of withstanding much greater stress without deforming and provides maximum vibration dampening.

1 Dual counterweight hydraulic cylinder

Z-axis is balanced with 2 sets of hydraulic cylinder weights to minimize the workload of the servo motor and extend the lifetime of ball screws and bearings.

2 Precision ground ball screws

C3 class hardened and precision ground ball screws ensure the highest accuracy and durability possible. Plus, pretension on all axes minimizes thermal distortion.

3 Direct drive servo motor

The axial system has an AC servo motor direct drive to provide great thrust and fast acc. / dec. movement. Plus, it efficiently decreases motor load and reduces generation of heat while maintaining ultimate performance and accuracy.

4 Live tooling spindle (opt.)

Equipped with optional live tooling, it can operate as a turning-milling machine that provides multiple machining functions, such as turning, milling, drilling, and tapping.



(Casting structure of GVF-2023 model shown)

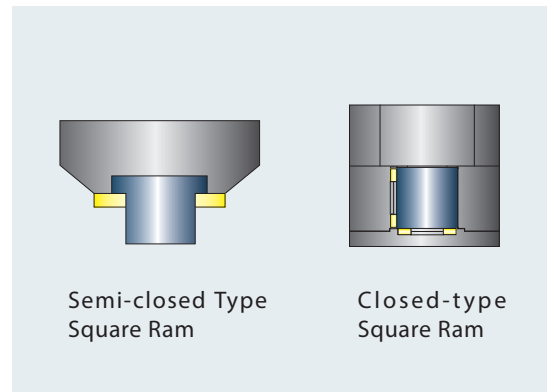
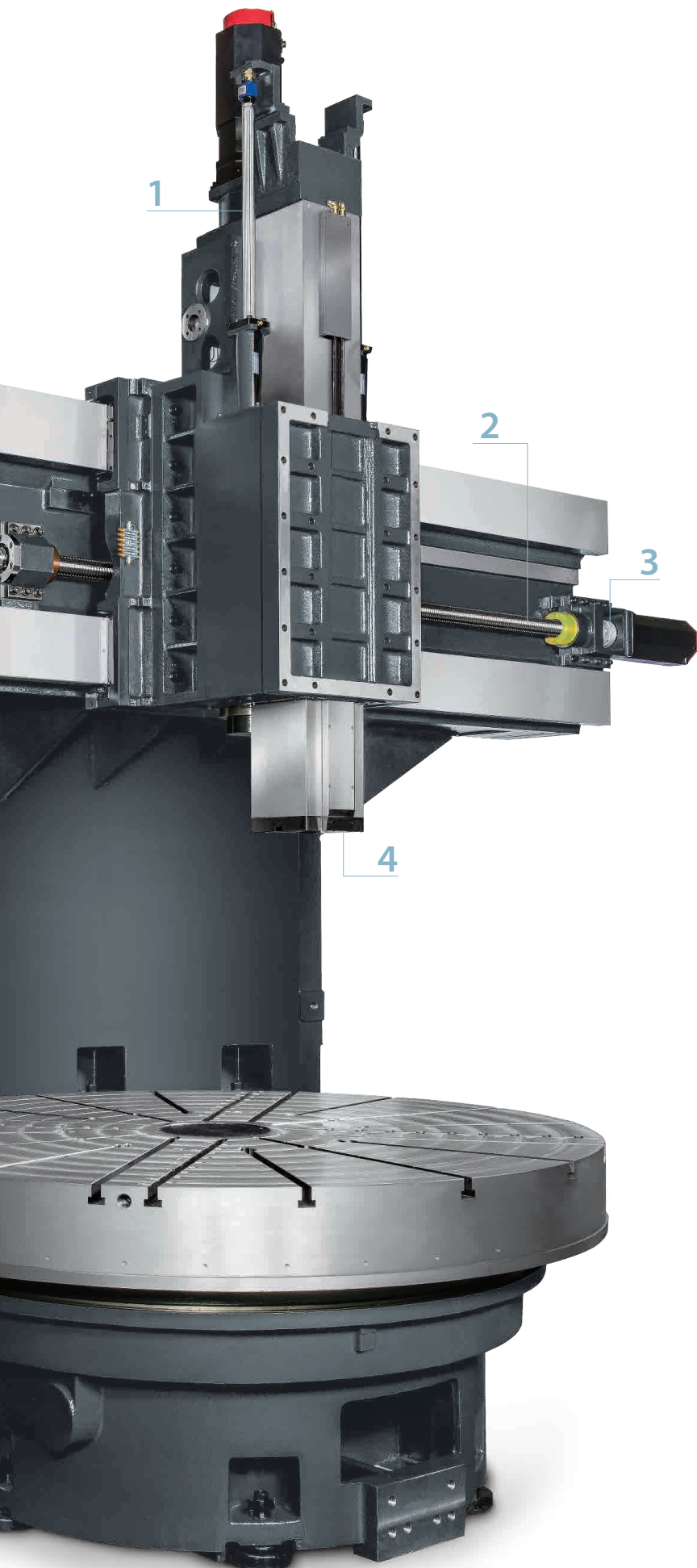

- ▶ The square ram on the tooling spindle has a closed-type design that gives the GVF series greater structural rigidity and machining accuracy compared to peer models with a semi-closed type square ram structure.



- ▶ Extra wide hardened and ground box ways design provides the rigidity needed for heavy duty and interrupted turning applications.



- ▶ Contact surfaces of all slides, spindles, ball screw bearing housings, bed and column are precision hand scraped to provide maximum assembly precision, structural rigidity, and load distribution.

WORK-PIECE SPINDLE

- ▶ The workpiece spindle uses a high-torque 2-speed gear box mated with a FANUC *αi* series spindle motor to provide 23,900 N-m extra large torque output on the low speed zone and satisfy different machining requirements.
- ▶ The rigid, cross roller spindle bearings can sustain radial, axial, and high torque loads while maintaining precision - even when the table has been carrying a maximum load for a long period of time.

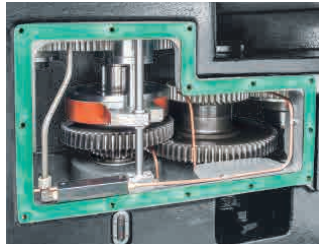

Work-Piece Spindle Output

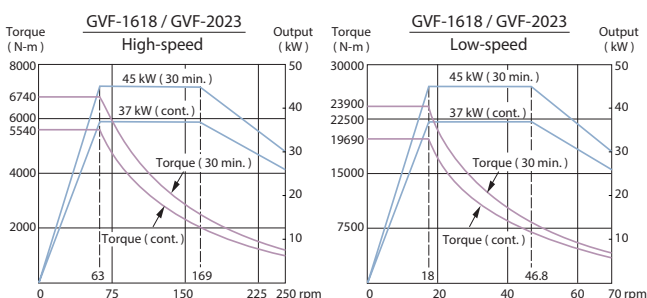
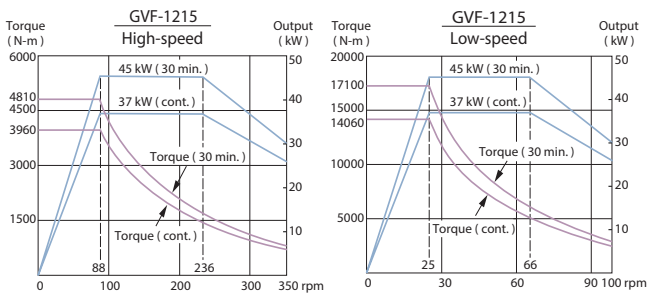
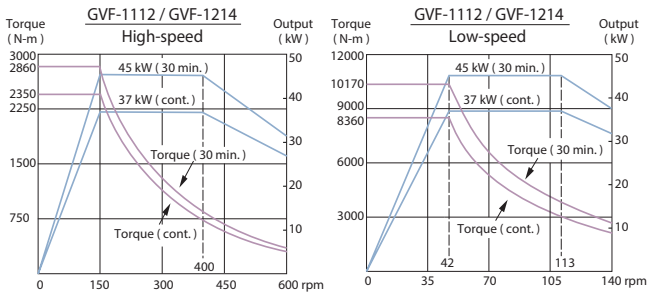

Clamping Range

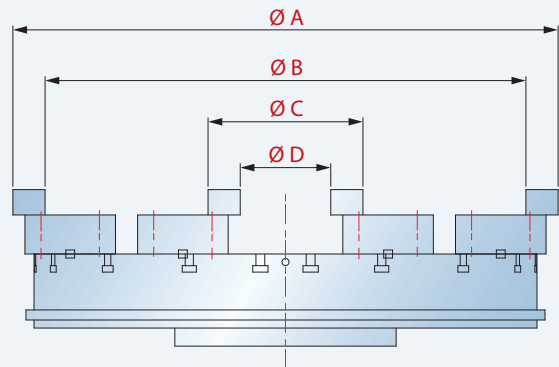

Unit : mm

Model	A	C
GVF-1112	1,165	355
GVF-1214	1,355	385
GVF-1215	1,355	385
GVF-1618	1,675	385
GVF-2023	2,075	385

Model	B	D
GVF-1112	1,005	195
GVF-1214	1,195	225
GVF-1215	1,195	225
GVF-1618	1,515	225
GVF-2023	1915	225

ULTIMATE C-AXIS CONTROL (OPT.)



- ▶ The optional Cf-axis and disk brake system available on the GVF series provide the most rigid and powerful type of C-axis on the market today. It has a worm gear drive system for high accuracy transmission and easy backlash adjustment. The indexing accuracy is up to 0.001°.

Cf-axis motor output

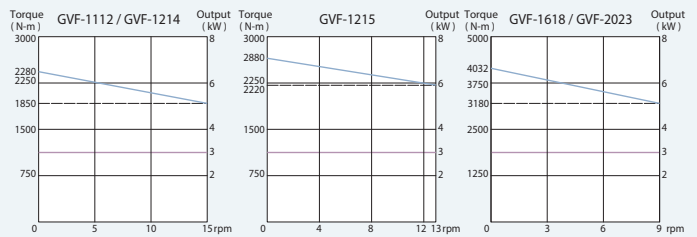

LIVE TOOLING SPINDLE (OPT.)

- ▶ The BT50 live tooling spindle is equipped with an extra high power spindle motor with a 2 setps gear box and max. 2,400 rpm speed to meet a variety of different applications such as turning, milling, drilling and tapping.
- ▶ Ø 90 mm NN TYPE roller bearings provides high rigidity, high precision and long life span advantages.



Tool presetter (opt.)

Tooling Spindle Ouput

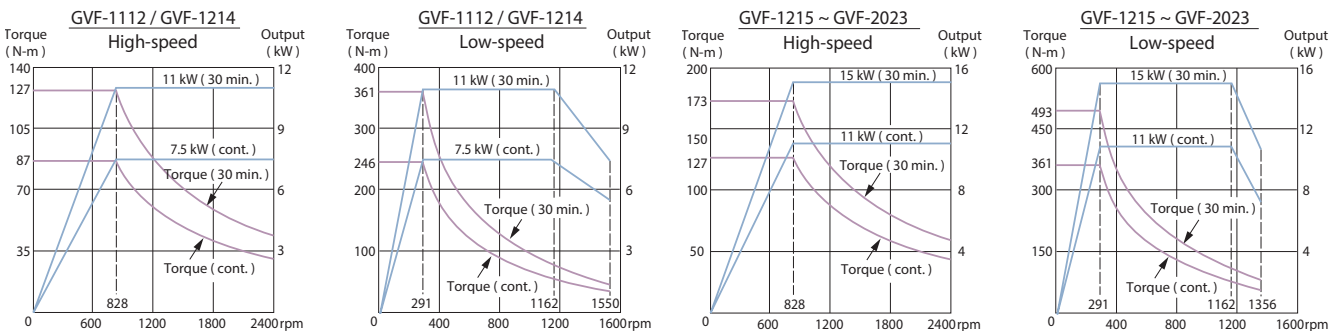

GENERAL DIMENSION

Tool Holders

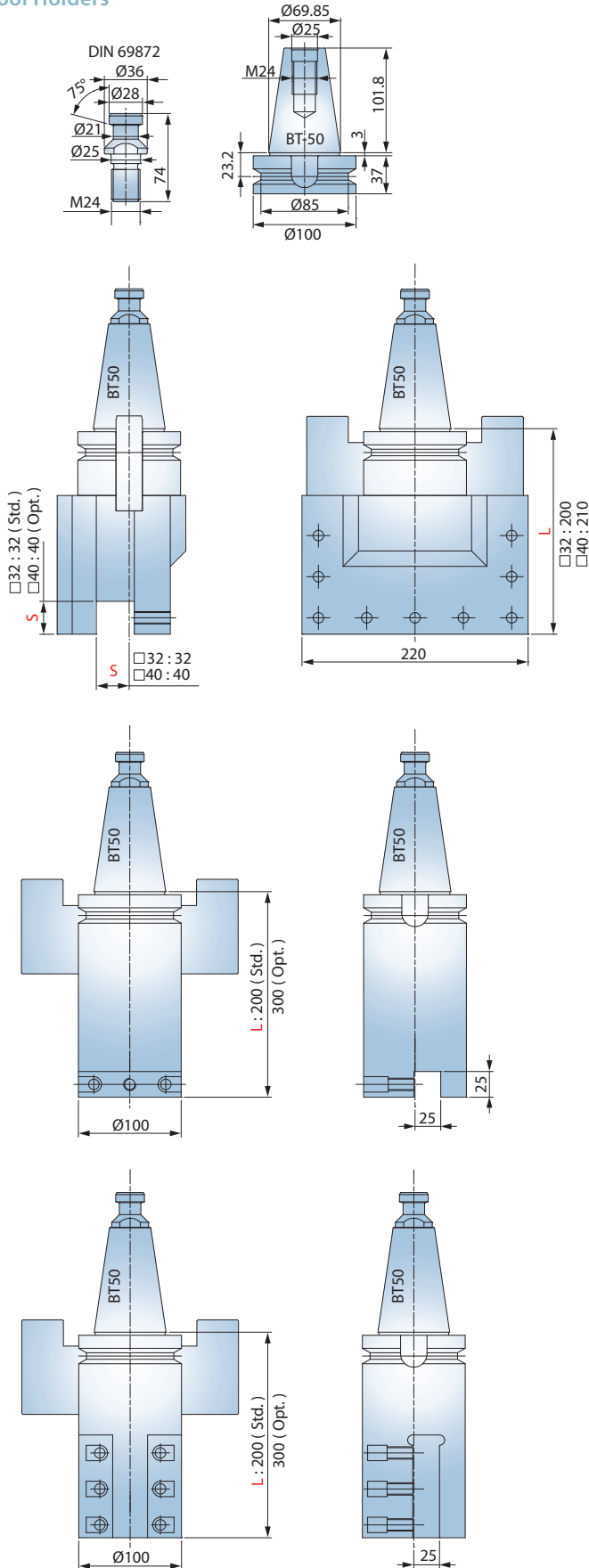

Tool Holders (Optional)

Unit : mm

Tapping tool holders

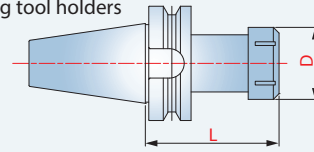

Item	L	D	Tapping Range
BT50-TER16	80	Ø28	M3-M12
BT50-TER40	117	Ø63	M12-M35

Drilling (collect type) tool holders

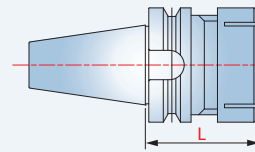

Item	L	Capacity	Collet Type
BT50-ER20-100	100	1-13	ER20
BT50-ER32-100	100	2-20	ER32
BT50-ER40-100	100	3-26	ER40

Drilling (side lock) tool holders

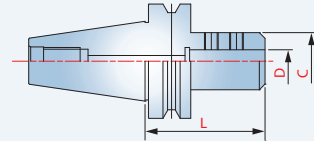

Item	L	C	D
BT50-SLA20-105	105	Ø50	Ø20
BT50-SLA25-105	105	Ø55	Ø25
BT50-SLA32-105	105	Ø60	Ø32
BT50-SLA40-105	105	Ø80	Ø40
BT50-SLA50.8-105	105	Ø95	Ø50.8

Face milling tool holders

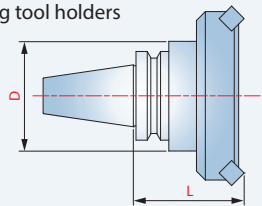

Item	L	D	Cutter Dia.
BT50-FMA25.4-105	125	Ø85	Ø80
BT50-FMA31.75-105	127	Ø85	Ø100
BT50-FMA38.1-75	98	Ø95	Ø125
BT50-FMA50.8-75	99	Ø95	Ø150

Boring tool holders

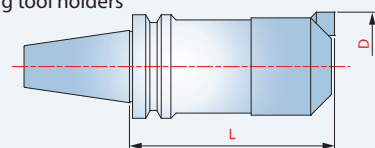

Item	L	D
BT50-BSA62-300	300	Ø62~90
BT50-BSA72-320	320	Ø72~110
BT50-FMA105-195	195	Ø105~160

Tooling System

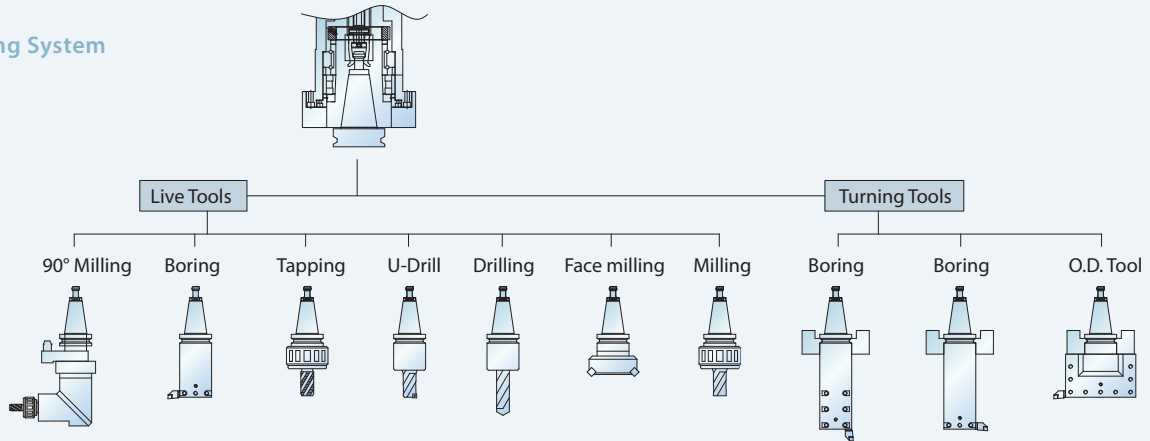

Machine Layout

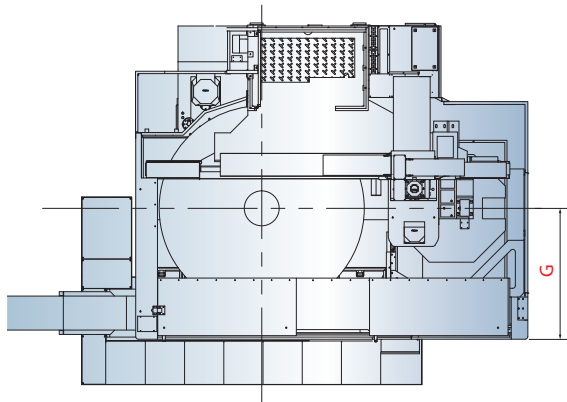

Work Range

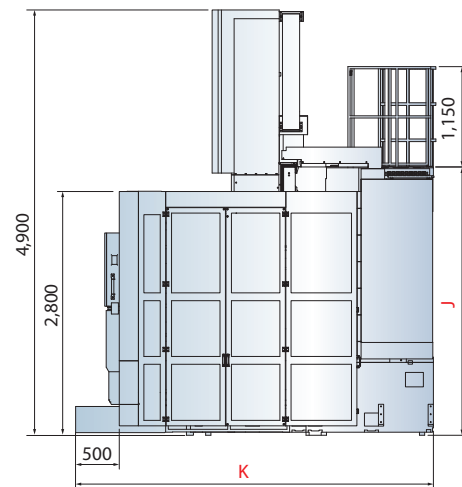
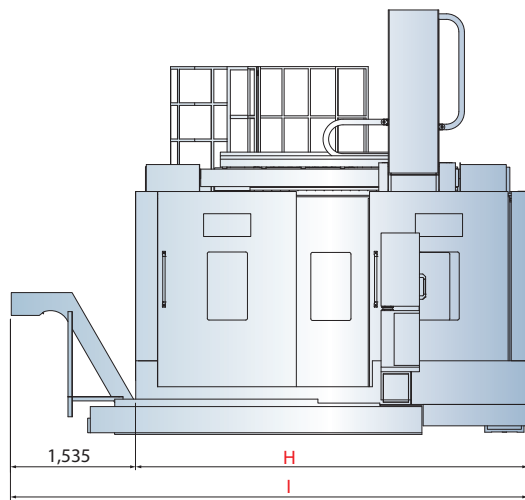
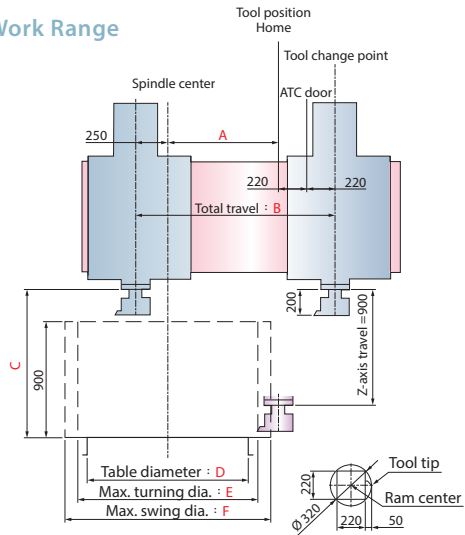

Unit : mm

Model	A	B	C	D	E	F	G	H	I	J	K
GVF-1112	760	1,450	1,150	Ø1,100	Ø1,200	Ø1,400	1,265	3,485	5,020	2,935	4,280
GVF-1214	860	1,550	1,150	Ø1,250	Ø1,400	Ø1,450	1,315	3,485	5,020	2,935	4,280
GVF-1215	910	1,600	1,150	Ø1,250	Ø1,400	Ø1,600	1,315	3,590	5,125	3,080	3,695
GVF-1618	1,060	1,750	1,150	Ø1,600	Ø1,800	Ø2,000	1,350	3,790	5,325	3,075	3,950
GVF-2023	1,310	2,000	1,135	Ø2,000	Ø2,300	Ø2,350	1,520	4,500	6,035	3,075	4,100

Specifications are subject to change without notice.

FEATURES

S : Standard O : Option
 - : Not available C : Contact GOODWAY

		GVF-112	GVF-124	GVF-125	GVF-1618	GVF-2023
WORK PIECE SPINDLE						
Main spindle		S	S	S	S	S
Rigid tapping		S	S	S	S	S
Cf-axis		O	O	O	O	O
Disk brake for main spindle		O	O	O	O	O
Lubrication system		S	S	S	S	S
WORK HOLDING						
4-jaws manual chuck		S	S	S	S	S
TOOLING SPINDLE						
BT50 spindle		S	S	S	S	S
Spindle Coolant		S	S	S	S	S
Coolant through spindle (CTS)		S	S	S	S	S
Live tooling spindle		O	O	O	O	O
12T magazine		S	S	O	O	O
16T magazine		O	O	S	S	S
24T magazine		-	-	O	O	O
MRASUREMENT						
Tool presetter		O	O	O	O	O
X & Z axes linear scales		O	O	O	O	O
Part presence check		O	O	O	O	O
COOLANT						
Coolant pump	10 Kg/cm ²	S	S	S	S	S
High-pressure coolant system	20 Kg/cm ²	O	O	O	O	O
Oil skimmer		O	O	O	O	O
Coolant flow switch		O	O	O	O	O
Coolant level switch		O	O	O	O	O
Coolant intercooler system		O	O	O	O	O
Paper tape filter		O	O	O	O	O
CHIP DISPOSAL						
Chip conveyor with auto timer		O	O	O	O	O
Chip cart		O	O	O	O	O
SAFETY						
Fully enclosed splash guard		S	S	S	S	S
Door interlock (incl. Mechanical lock)		S	S	S	S	S
Impact resistant viewing window		S	S	S	S	S
Low hydraulic pressure detection switch		S	S	S	S	S
Over travel (soft limit)		S	S	S	S	S
Auto power-off device		S	S	S	S	S
OTHERS						
Tri-color operation status signal light tower		S	S	S	S	S
Fluorescent work light		S	S	S	S	S
Electrical cabinet	Heat exchanger	S	S	S	S	S
	A / C cooling system	O	O	O	O	O
Complete hydraulic system		S	S	S	S	S
Advanced auto lubrication system		S	S	S	S	S
Emergency maintenance electrical part package		S	S	S	S	S
Operation & maintenance manuals		S	S	S	S	S

FANUC CONTROL FUNCTIONS

		O _i -TF	31 _i
Display	8.4" color LCD	S	-
	10.4" color LCD	-	S
Graphic function	Standard	S	S
	Dynamic*1	O	O
Part program storage size	512K bytes	S	-
	1M bytes	-	S
	O _i -TF : each path	O	O
	31 _i : total	-	O
Registerable programs	8M bytes	-	O
	400	S	-
	O _i -TF : each path	O	S
31 _i : total	1,000	-	O
	4,000	-	O
	99	-	S
	128	S	-
Tool offset pairs	200	O	O
	O _i -TF : each path	-	O
31 _i : total	400	-	O
	499	-	O
	999	-	O
	2000	-	O
Servo HRV control	HRV 3	S	S
Automatic data backup		S	S
Synchronous / Composite control		O	O
Inch / metric conversion		S	S
Polar coordinate interpolation		S	S
Cylindrical interpolation		S	S
Multiple repetitive cycle		S	S
Rigid tapping		S	S
Unexpected disturbance torque detection function		S	S
Spindle orientation		S	S
Spindle speed fluctuation detection		S	S
Embedded macro		O	O
Spindle synchronous control		S	S
Run hour and parts count display		S	S
Tool radius / Tool nose radius compensation		S	S
Polygon turning		S	S
Helical interpolation		O	O
Direct drawing dimension programming		S	S
Thread cutting retract		S	S
Variable lead threading		S	S
Multiple repetitive cycle II		S	S
Canned cycles for drilling		S	S
Tool nose radius compensation		S	S
Chamfering / Corner R		S	S
AI contour control I		O	S
Multi part program editing*2		S	S
Manual handle retrace		O	O
Manual intervention and return		S	O
External data input		S	S
Addition of custom macro		S	S
Increment system C		S	S
Run hour & parts counter		S	S
Auto power-off function		S	S
RS-232 port		S	S
Memory card input / output (CF + USB)		S	S
Ethernet		S	S

*1 Dynamic graphic display conflict to MANUAL GUIDE *i*, only can choose one to have.

MANUAL GUIDE *i* is standard on 31_i controller.

*2 10.4" LCD option needed

Specifications are subject to change without notice.

MACHINE SPECIFICATIONS

CAPACITY	GVF-1112	GVF-1214	GVF-1215	GVF-1618	GVF-2023
Table diameter	Ø 1,100 mm 43.3"	Ø 1,250 mm 49.2"	Ø 1,250 mm 49.2"	Ø 1,600 mm 62.9"	Ø 2,000 mm 78.7"
Max. swing diameter	Ø 1,400 mm 55.1"	Ø 1,450 mm 57"	Ø 1,600 mm 62.9"	Ø 2,000 mm 78.7"	Ø 2,350 mm 92.5"
Max. turning diameter	Ø 1,200 mm 47.2"	Ø 1,400 mm 55.1"	Ø 1,500 mm 59"	Ø 1,800 mm 70.8"	Ø 2,300 mm 90.5"
Max. turning height	900 mm 35.4"	900 mm 35.4"	900 mm 35.4"	900 mm 35.4"	900 mm 35.4"
Max. table load	4,000 kg 8,800 lb	3,700 kg 8,100 lb	5,000 kg 11,000 lb	8,000 kg 17,600 lb	5,000 / 8,000 kg (OP.) 11,000 / 17,600 lb (OP.)
WORK-PIECE SPINDLE					
Spindle bearing diameter	Ø 350 mm 13.7"	Ø 350 mm 13.7"	Ø 423 mm 16.6"	Ø 580 mm 22.8"	Ø 580 / Ø 690 mm (OP.) 22.8" / 27.1" (OP.)
Motor output (Cont. / 30 min.)	37 / 45 kW 50 / 60 HP				
Gear step	2-speed				
Spindle speed range	1 ~ 500 rpm	1 ~ 350 rpm	1 ~ 350 rpm	1 ~ 250 rpm	1 ~ 200 rpm
Max. spindle torque	10,170 Nm 7,500 lb-ft	10,170 Nm 7,500 lb-ft	17,100 Nm 12,610 lb-ft	23,900 Nm 17,625 lb-ft	
TOOLING SPINDLE (OPTIONAL)					
Motor output (Cont. / 30 min.)	7.5 / 11 kW 10 / 15 HP		11 / 15 kW 15 / 20 HP		
Gear step	2-speed				
Spindle speed range	1 ~ 2,400 rpm				
Max. spindle torque	361 Nm 265 lb-ft		493 Nm 360 lb-ft		
CF-AXIS (OPTIONAL)					
Cf-axis motor output	3 kW 4 HP				
Cf-axis torque output	2,280 Nm 1,680 lb-ft	2,280 Nm 1,680 lb-ft	2,880 Nm 2,120 lb-ft	4,030 Nm 2,970 lb-ft	4,030 Nm 2,970 lb-ft
Cf-axis speed range	15 rpm	15 rpm	13 rpm	9 rpm	9 rpm
X & Z AXES					
Max. X-axis travel	1,450 (-250 ~ +1,200) mm 57" (-9.8" ~ 47.2")	1,550 (-250 ~ +1,300) mm 61" (-9.8" ~ 51.1")	1,600 (-250 ~ +1,350) mm 62" (-9.8" ~ 53.1")	1,750 (-250 ~ +1,500) mm 68.8" (-9.8" ~ 59")	2,000 (-250 ~ +1,750) mm 78.7" (-9.8" ~ 68.8")
Max. Z-axis travel	900 mm 35.4"				
X / Z axes rapids	12 / 10 m/min 472 / 393 IPM				
X / Z axes motor output	7 / 9 kW 9.3 / 12 HP		6 / 9 kW 8 / 12 HP		
ATC					
Magazine capacity	12 T		16 T		
Spindle taper	BT50				
Max. tool size	280 x 150 x 400 mm 11" x 5.9" x 15.7"				
Max. tool weight / magazine load	50 / 360 kg 110 / 793 lb				
GENERAL					
X / Z axes positioning accuracy	± 0.007 / 500 mm ± 0.0003" / 19.7"				
X / Z axes repeatability	± 0.005 mm ± 0.0002"				
Cf-axis positioning accuracy	± 7.5"				
Cf-axis repeatability	± 5"				
NC controller	FANUC Oi-TF				
Voltage / Power requirement	AC200 / 220 + 10% to - 15 % 3 phase / 100 kVA				
Hydraulic capacity	50 L 13 gal				
Coolant tank capacity	900 L 237 gal				
Machine weight	20,000 kg 44,100 lb	21,500 kg 47,400 lb	21,500 kg 47,400 lb	23,500 kg 52,000 lb	25,000 kg 55,200 lb
Dimensions L x W x H	5,020 x 4,280 x 4,900 mm 198" x 169" x 193"	5,020 x 4,280 x 4,900 mm 198" x 169" x 193"	5,125 x 3,695 x 4,900 mm 202" x 146" x 193"	5,325 x 3,950 x 4,900 mm 210" x 156" x 193"	6,035 x 4,100 x 4,900 mm 238" x 162" x 193"



GOODWAY MACHINE CORP.



GOODWAYCNC.com

Official distributor for Benelux



THOLITEC

Jan Doustraat 37
1689 XK Zwaag (NH)
The Netherlands

Tel. +31(0)85 0022937
info@tholitec.nl
www.tholitec.nl