

GV-1000 SERIES

Super Rigid Vertical CNC Turning Centers



THE ULTIMATE MACHINING POWER
WOODWAY®

SUPER RIGID VERTICAL CNC TURNING CENTERS

With 40 years of experience in lathe manufacturing, GOODWAY is pleased to introduce our GV-1000 Vertical CNC Turning Center. With a combination of ultra-high power performance, super rigid construction, and high speed machining, the GV-1000 provides the turning and milling capacity for the dynamic demands of today and tomorrow's market.

With a maximum turning diameter of 1,000 mm by 760 mm height, the GV-1000 is ideal for the machining of large parts and heavy cutting conditions. The C-axis and a live tooling turret enable " One Hit Manufacturing " of suitable components.



- ▶ Fully enclosed guarding for a clean environment.
- ▶ The use of steel made slide way covers protect all the axial ways.
- ▶ Environmentally friendly lube system provides the lubrication for the slide-ways and ball-screws.

(GV-1000M model shown with optional accessories)

GV-1000 SERIES

Model	GV-1000	GV-1000M	GV-1000M/ATC
Max. swing diameter		Ø 1,020 mm	
Max. turning diameter		Ø 1,000 mm	
Max. turning height	760 mm		700 mm
Live tooling turret & C-axis	—	Std.	—
Tooling spindle	—	—	Std.



- ▶ Designed for the easy loading of parts, the spindle nose to floor = 1,080 mm and the spindle center line to the operator door = 671 mm
- ▶ The compact body design and working area make the GV-1000 foot print one of the smallest in its class.

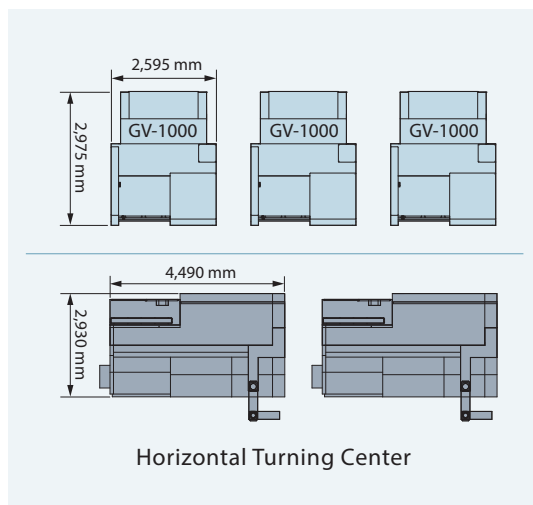

(GV-1000M/ATC model shown with optional accessories)

- ▶ The spindle gear box lubrication integrity is monitored by flow.
- ▶ Easy maintenance independent coolant system and chip conveyor.



Flow Detector



Coolant tank



Chip conveyor

SUPER RIGID CONSTRUCTION

- ▶ The base and column construction has been made by computer generated design which has increased the stability by 30% over traditional design.
- ▶ Meehanite grade castings, rib and reinforced provide excellent stability, good thermal expansion and performance for the vertical column.
- ▶ FANUC αi series AC servo motors are fitted to all axes. The αPi intelligent servo motor with its compact size and super high resolution αi series pulsecoder (standard 1,000,000 / rev) are the perfect partner in this machine tool.

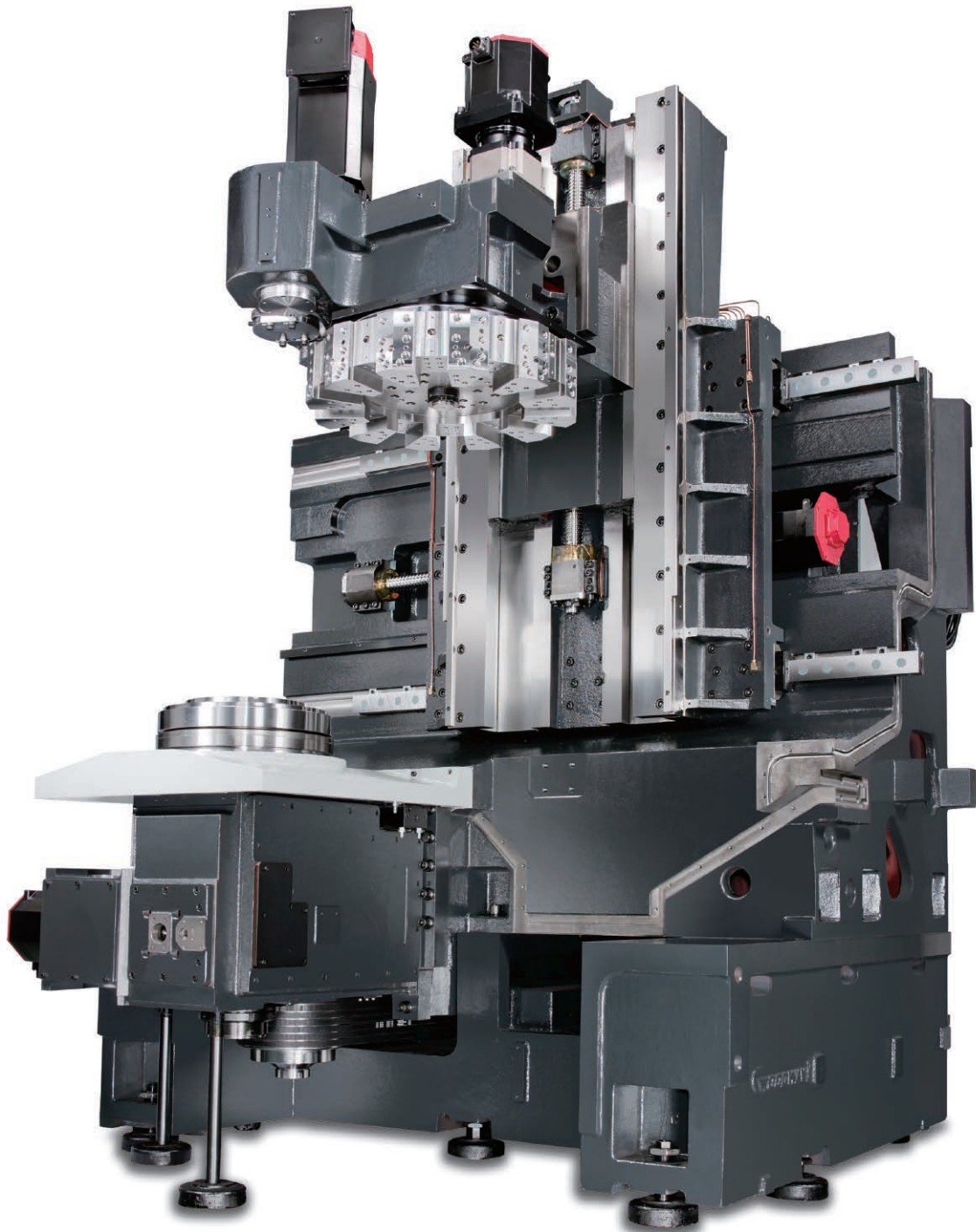

(Casting structure of GV-1000 model shown)

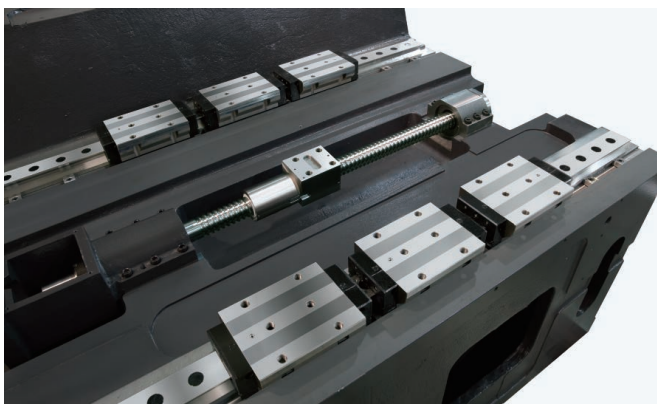

- ▶ Super rigid roller type linear guide ways on X-axis offer heavy-duty cutting, fast movement and low abrasion capabilities.

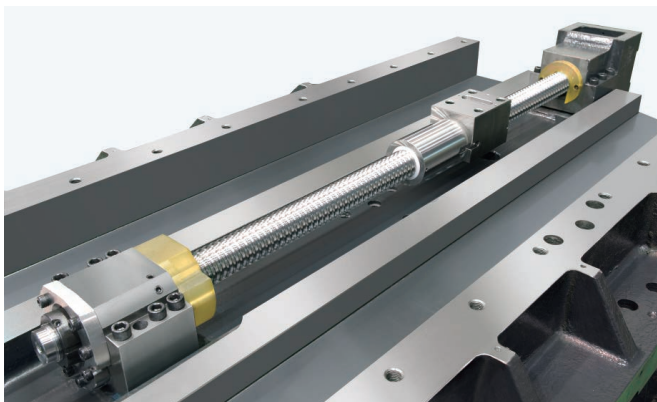

- ▶ C3 class ball screws (with a pitch accuracy of $12.7 \mu / 300 \text{ mm}$) are fitted with pre-load to X & Z axes.
- ▶ Extra wide hardened and ground box ways on Z-axis suitable for heavy-duty cutting need.

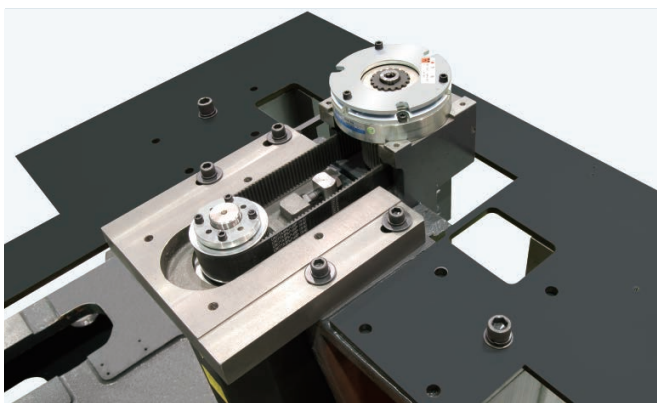

- ▶ The Z-axis is fitted with an independent Japan made brake system.

- ▶ Contact surfaces of all slide, turret and ball screw bearing housings with the machine bed are precision hand scraped to provide maximum assembly precision, structural rigidity, and load distribution.



ULTIMATE TURNING POWER

- ▶ Bearing configuration : Front – Double roller × 1
Angular contact × 2
Rear – Double roller × 1

- ▶ P4 grade (Class 7) super-high precision bearings are directly assembled for maximum level of support and precision. Bearing configuration is designed for super heavy-duty cutting with ultra-smooth performance and long term durability with a higher level of accuracy.

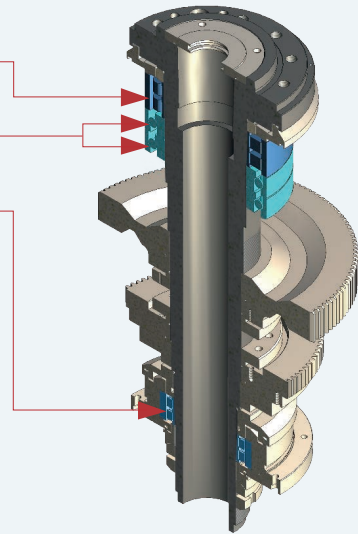

- ▶ The 2-step gear box produces 30 kW of output.
- ▶ With over 3,765 N-m of torque available on the low speed of the 2-speed gear head, turning tough material with big diameter is now a simple task.

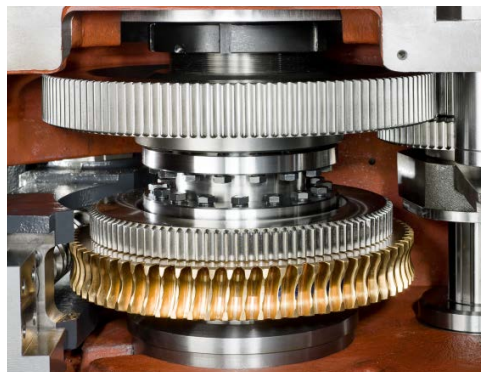

- ▶ Generating twice the torque output of standard motors, the A/C, constant output, wide-range FANUC high-torque *i* series motor is rated at 30 kW (40 HP). This doublewound motor is designed to reach full output at 1/2 the RPM of standard motors, providing the ability to take heavier cuts in the lower RPM ranges.
- ▶ Standard spindle orientation feature allows the spindle to stop at desired programmed position. Useful in broaching and manual part loading applications where a fixed spindle position is required.





Work piece shown



Spindle motor output

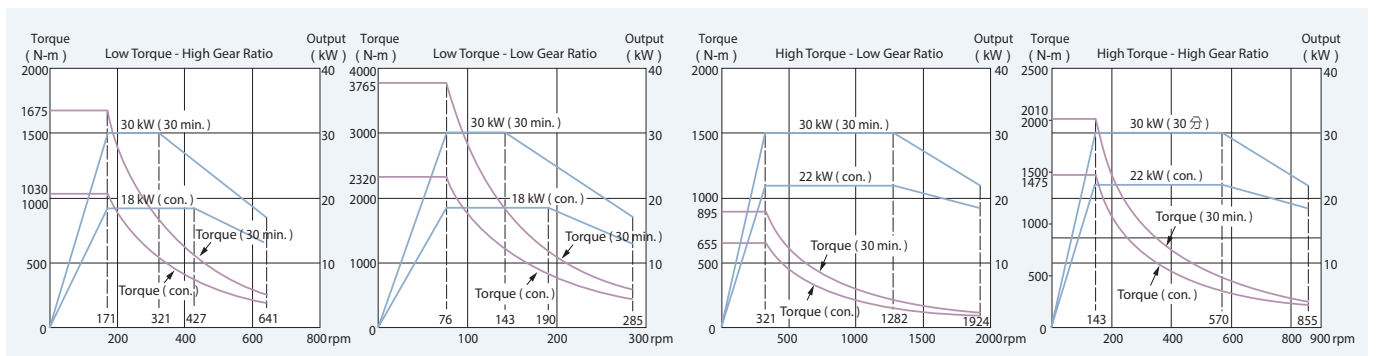

ADVANCED TURRET TECHNOLOGY

- ▶ The index position of the turret is by the large \varnothing 320 mm diameter curvic coupling.
- ▶ Available with straight and 90° live tooling tool holder.
- ▶ Live tooling drive by FANUC Servo Motor.

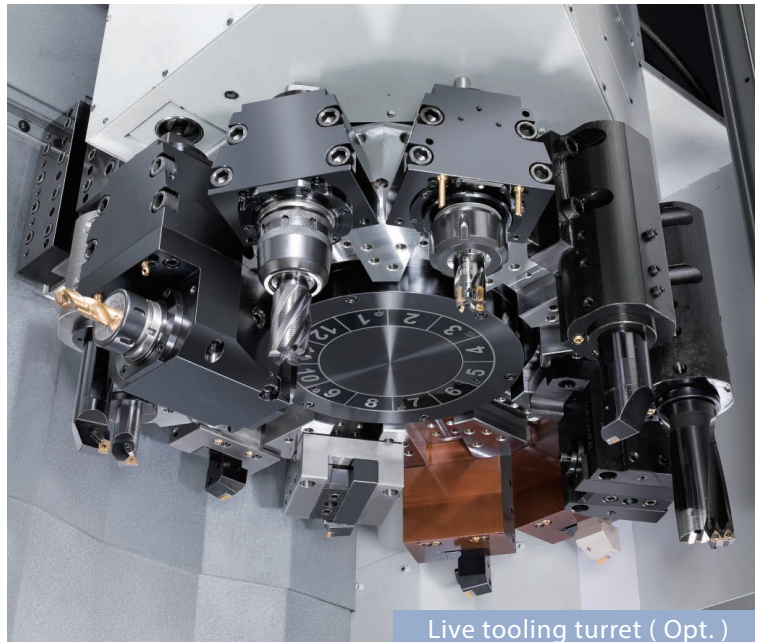
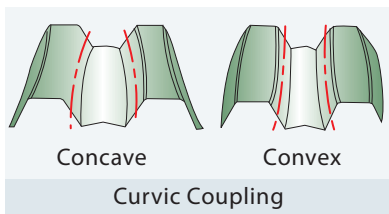

Live tooling turret (Opt.)

ULTIMATE C-AXIS SPINDLE

- ▶ The Cf-axis and disk brake system available on the GV-1000 series provides the most rigid and powerful type of C-axis on the market today.
- ▶ Working with the live tooling turret, the Cf-axis and disk brake system enables the machine to perform multiple tasks, such as drilling, tapping, and milling operations, including cylindrical and polar coordinate interpolations.



Worm gear transmission system

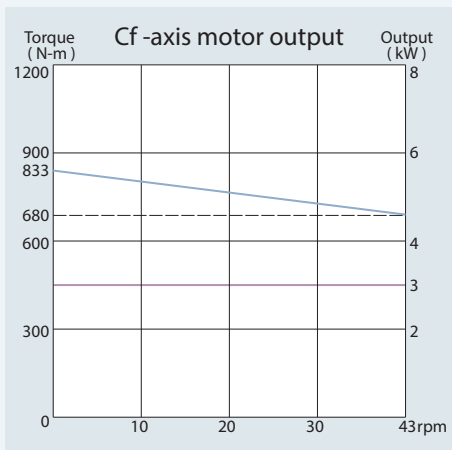

- ▶ With the FANUC servo motor generating an ultra high resolution of 120 million pulses per spindle rotation and 833 N-m of torque (Cont.), machined surface finishes can reach to a higher accuracy level. Plus, dynamic accuracy is within $\pm 0.02^\circ$.

Tooling System

Standard Turret

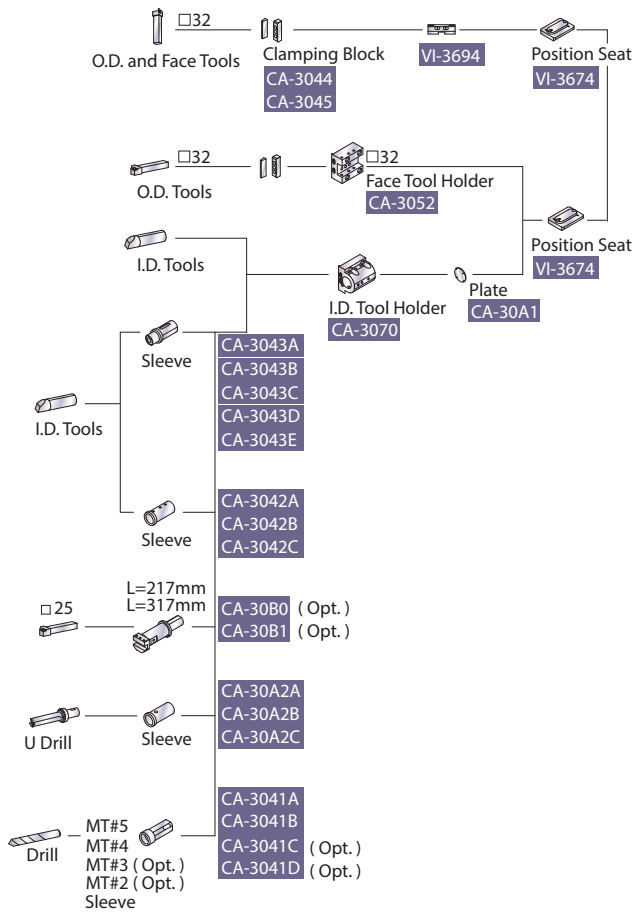

Live Tooling Turret

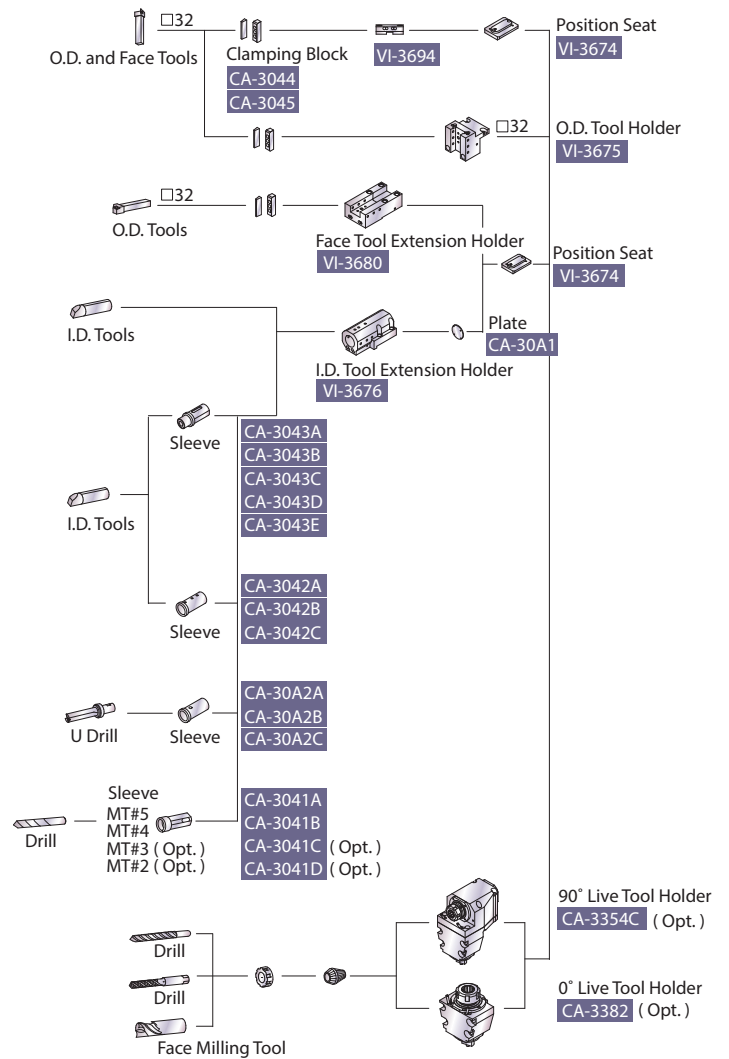

Machine Layout

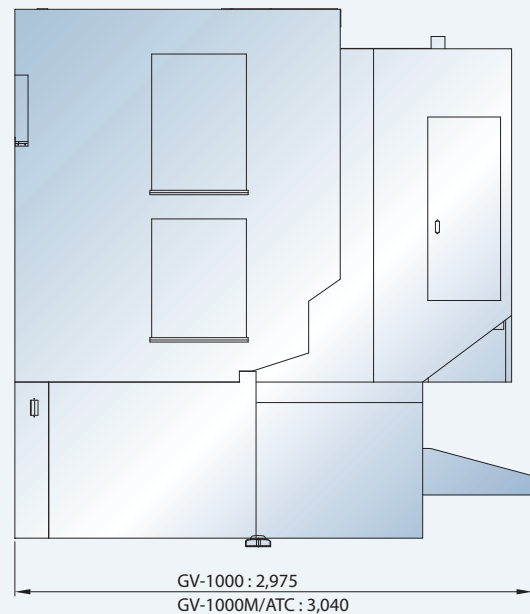
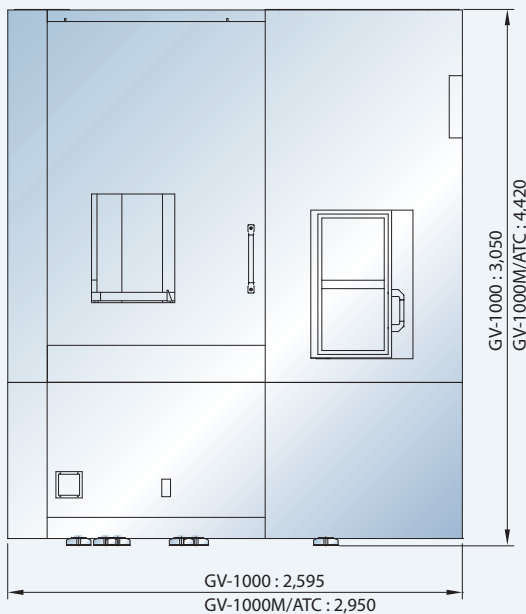

Unit : mm

MACHINE SPECIFICATIONS

CAPACITY	GV-1000	GV-1000M/ATC
Max. swing diameter		Ø 1,020 mm
Max. turning diameter		Ø 1,000 mm
Std. turning diameter	Ø 330 mm	—
Max. turning height	760 mm	700 mm
Hydraulic chuck size	15" ~ 32"	15" ~ 32"
SPINDLE		
Spindle bearing diameter		Ø 200 mm
Spindle nose		A2-15
Motor output (Cont. / 30 min.)		22 / 30 kW
Motor full output speed		400 rpm
Spindle drive system		Belt + Gear
Gear Step		2
Spindle speed range		20 ~ 2,000 rpm (15" , 18" chuck) 15 ~ 1,500 rpm (21" , 24" chuck) 15 ~ 1,000 rpm (32" chuck)
Spindle full output speed		76 rpm
Spindle torque (Cont. / 30 min.)		2,320 / 3,765 N-m
X & Z AXES		
X / Z axes travel	525 / 765 mm	750 / 850 mm
X / Z axes rapids	24 / 20 m/min.	24 / 20 m/min.
X / Z axes servo motor	4 / 6 kW	4 / 6 kW
TURRET		
Stations	12	—
Indexing speed	1.5 sec. Adjacent	—
OD / ID tool shank size	<input type="checkbox"/> 32 / Ø 60 mm	—
LIVE TOOLING TURRET (OPTIONAL)		
Stations	12	—
Live tooling stations	12 (rotate in working position only)	—
Live tooling drive motor	3.7 / 5.5 kW	—
Index speed	1.5 sec. (Adjacent)	—
OD / ID tool shank size	<input type="checkbox"/> 32 / Ø 60 mm	—
Live tooling shank size	ER 50 / ER 40 (0° / 90°)	—
Live tooling RPM range	3,000 rpm	—
TOOLING SPINDLE (OPTIONAL)		
Spindle bearing diameter	—	90 mm
Motor output (Cont. / 30 min.)	—	11 / 7.5 kW
Motor full output speed	—	1,500 rpm
Spindle drive system	—	Direct Belt Drive
Spindle speed range	—	2,400 rpm
Spindle torque (Cont. / 30 min.)	—	95 / 140 N-m
ATC		
Magazine capacity	—	12
Spindle taper	—	BT50
Cf-AXIS		
Cf-axis drive motor		3 kW
Cf-axis drive ratio		1 : 70
Cf speed range		30 rpm
Cf-axis torque output (Cont.)		883 N-m
Indexing angle / Dynamic accuracy		± 0.02° / ± 0.01°
GENERAL		
Control	FANUC Oi-TF (Opt. 31 i)	
Voltage / Power requirement	AC 200 / 220 + 10% to -15% 3 phase / 58 KVA	
Hydraulic / Coolant tank capacity	30 / 250 L	
Coolant pump / pressure	Cutting Coolant : 1.2 kW / 10 Kg/cm ² ; Washing Coolant : 1 kW / 5 Kg/cm ²	
Machine weight	13,500 Kg	14,000 Kg
Dimensions L × W × H	2,595 x 2,975 x 3,050 mm	2,950 x 3,040 x 4,420 mm

Specifications are subject to change without notice.



GOODWAY MACHINE CORP.



GOODWAYCNC.com

Official distributor for Benelux



Jan Doustraat 37
1689 XK Zwaag (NH)
The Netherlands

Tel. +31(0)85 0022937
info@tholitec.nl
www.tholitec.nl